

MAKİNANIN TEKNİK BİLGİLERİ VE MONTAJ ÖLÇÜLERİ
DIMENSIONS & TECHNICAL DATA

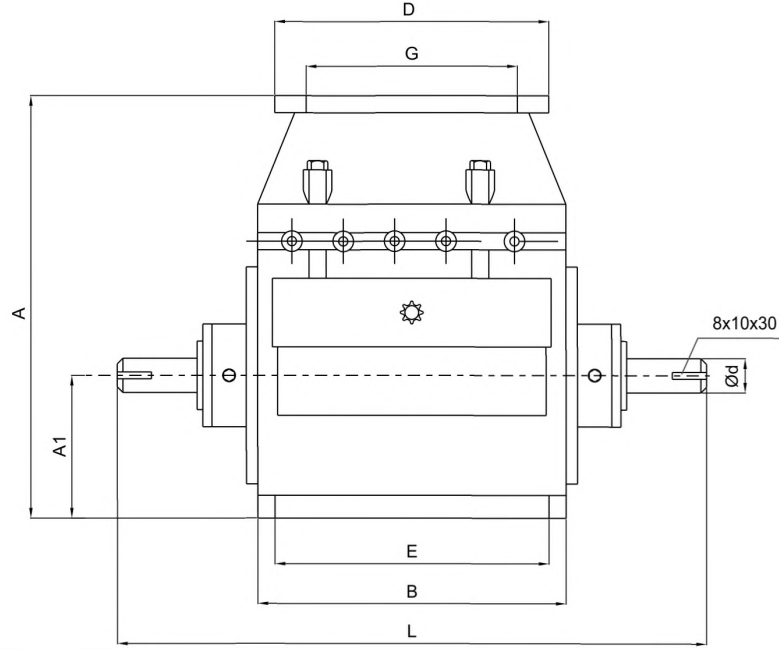

PAÇAL MAKİNALARININ KAPASİTE ÇİZELGESİ / CAPACITY TABLE FOR VOLUME MEASURES

MODEL TYPE	MORA-L			MORA-P			%
	KAPASİTE / CAPACITY Kg / h			KAPASİTE / CAPACITY Kg / h			
SÜRGÜ GATE	1 d/d (rpm)	40 d/d (rpm)	50 d/d (rpm)	1 d/d (rpm)	40 d/d (rpm)	50 d/d (rpm)	
1	0.085	204	255	0.25	600	750	5
2	0.17	408	510	0.5	1200	1500	10
3	0.34	816	1.020	1	2400	3000	20
4	0.34	816	1.020	1	2400	3000	20
5	0.72	1.728	1.020	2.25	5400	6750	45
TOPLAM / TOTAL (kg)	1.65	3.972	4.965	5	12000	13000	100

ÖLÇÜLER / DIMENSIONS (mm)

MODEL TYPE	A	A1	B	C	D	D1	Ød	E	E1	F	G	G1	L	Ağırlık Weights (kg)
MR - L	365	125	260	270	240	168	30	242	165	340	185	115	555	80
MR - P	373	145	355	290	320	165	35	315	210	360	265	120	697	115